



# JF MIX V DUO 7000 11000

Vertical Mixers



## The main ingredient for a successful farming recipe!

JF's DUO Vertical Mixers bring to the market the most significant innovation in recent years: A mixer featuring a double auger system that ensures a homogeneous mix with much more speed and efficiency to feed every animal from the first to the last with the same feeding quality.

## Features

- ✓ DUO MOVmix® technology ensures efficient mixing with a low coefficient of variation throughout the entire tank, even near the walls;
- ✓ High-strength and durable planetary transmission with 2 mixing speeds;
- ✓ Blades and counter blades with multiple adjustment positions for better mix adaptation.
- ✓ High-flotation tires

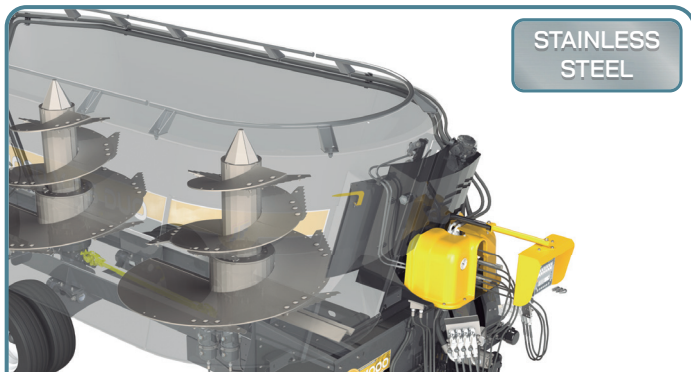

STAINLESS STEEL

Innovative system with 2 augers - faster and more homogeneous mixing.



Discharge for both sides through conveyor



Planetary Transmission: 2 speeds

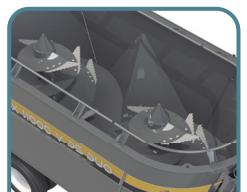

Stainless steel mixing tank.

## TECHNICAL SPECIFICATIONS

7000

11000

⏻ Drive	tractor-mounted	tractor-mounted
📊 Capacity	7m <sup>3</sup>	11m <sup>3</sup>
↻ Required rotation at PTO	540 RPM	540 RPM
⚡ Required power at TO	from 70hp	from 80hp
🛞 Tires	11L15 (12 CANVAS) HIGH-FLOTATION	11L15 (12 CANVAS) HIGH-FLOTATION
📏 Approximate Weight	2502kg	3206kg
⚙️ Discharge configuration	discharge by belt, both sides (hydraulic)	discharge by belt, both sides (hydraulic)